



## ROLLCABS

Thank you for purchasing a Sealey product. Manufactured to a high standard, this product will, if used according to these instructions, and properly maintained, give you years of trouble free performance.

**IMPORTANT:** PLEASE READ THESE INSTRUCTIONS CAREFULLY. NOTE THE SAFE OPERATIONAL REQUIREMENTS, WARNINGS & CAUTIONS. USE THE PRODUCT CORRECTLY AND WITH CARE FOR THE PURPOSE FOR WHICH IT IS INTENDED. FAILURE TO DO SO MAY CAUSE DAMAGE AND/OR PERSONAL INJURY AND WILL INVALIDATE THE WARRANTY. KEEP THESE INSTRUCTIONS SAFE FOR FUTURE USE.



Refer to instructions



Wear protective gloves



Wear safety footwear

### 1. SAFETY

- × To avoid tipping, **DO NOT** open more than one drawer at a time.
- × **DO NOT** climb on the drawers or cabinet
- ✓ Close and secure all drawers when moving.

### 2. ASSEMBLY

- 2.1. Attach the castors to the bottom of the trolley using 4 bolts per castor (fig.1).  
**NOTE:** Swivel castors should be mounted at the same side as the handle (left hand side).
- 2.2. Insert the side mounted handle into the cabinet and attach with 4 bolts and washers (fig.2).  
**NOTE:** The side handle should be mounted on the same side as the swivel castors (left hand side).
- 2.3. To remove a drawer with the roller slides, pull the drawer completely out, press down the left tab and lift up the right tab, pull drawer off the slides. To reinstall the drawer, realign with the internal drawer slide and push until it locks in place (fig.3).

### 3. MAINTENANCE

- 3.1. Lubricate castors periodically and tighten all the nuts and bolts.

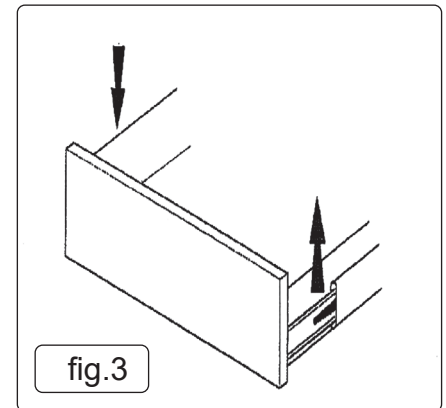
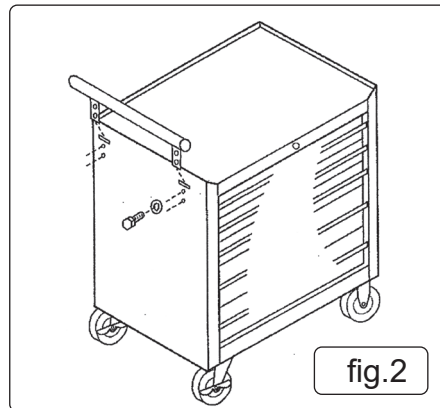
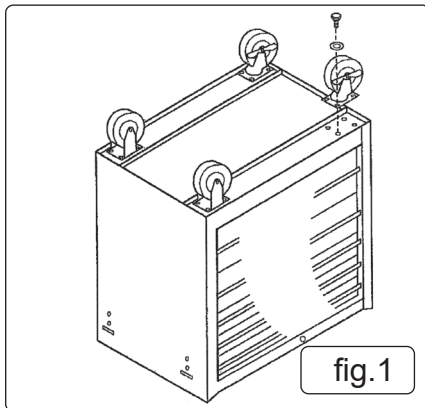

#### ENVIRONMENT PROTECTION

Recycle unwanted materials instead of disposing of them as waste. All tools, accessories and packaging should be sorted, taken to a recycling centre and disposed of in a manner which is compatible with the environment. When the product becomes completely unserviceable and requires disposal, drain any fluids (if applicable) into approved containers and dispose of the product and fluids according to local regulations.

**Note:** It is our policy to continually improve products and as such we reserve the right to alter data, specifications and component parts without prior notice.

**Important:** No Liability is accepted for incorrect use of this product.

**Warranty:** Guarantee is 12 months from purchase date, proof of which is required for any claim.

Sealey Group, Kempson Way, Suffolk Business Park, Bury St Edmunds, Suffolk. IP32 7AR

01284 757500



sales@sealey.co.uk



www.sealey.co.uk